



**“HOT SWAPPABLE” BLOCK CONVERTERS,  
CONVERTER TRAYS WITH INDEPENDENT OPERATION**

These block converter systems provide frequency translation between the transponder band and L-band frequencies.

The two independent converter assemblies are “hot swappable” through the rear of the chassis. Each converter tray has independent control of the front panel. The front panel can be replaced without loss of signal.

**DUAL CHANNEL STANDARD FEATURES**

- Hot swappable independent converter trays with power supplies and reference oscillators.
- RS422, RS485 and 10/100 Base-T Ethernet
- Amplitude slope adjust
- Low phase noise, better than IESS-308/309
- Low intermodulation distortion
- 30 dB level control
- Summary Alarm
- CE Mark

**DUAL CHANNEL OPTIONS**

- Reference clean-up loop and improved stability
- Lower gain
- High Performance Package
- Lower phase noise (included with high performance package)

**DUAL CHANNEL CONFIGURATION**

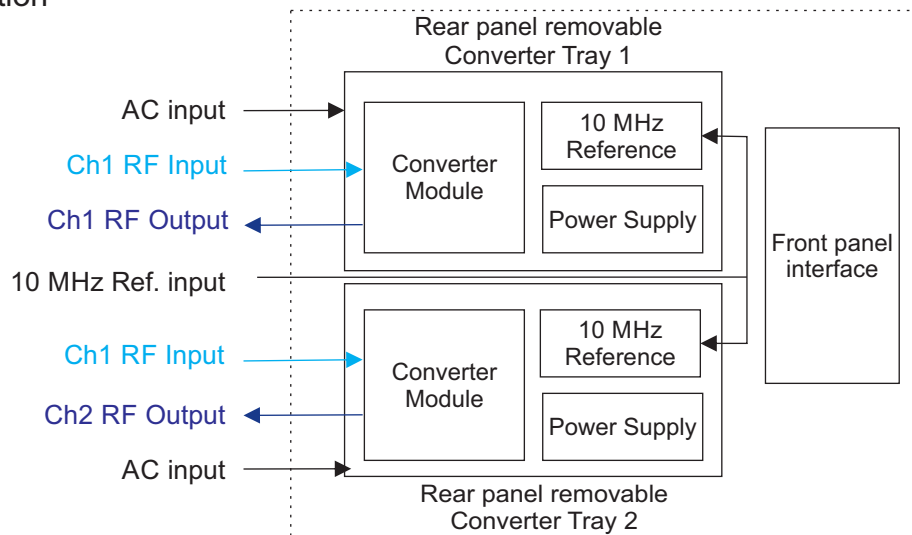

## BLOCK DOWNCONVERTERS

Input (GHz)	Output (GHz)	LO (GHz)	Conv Tray Model #
1.5 – 2.55	0.95 – 2	10.45/11	D2.025
2 – 2.4	0.95 – 1.35	3.85/4.9	D2.2
3.4 – 4.2	0.95 – 1.75	5.15	D3.8INV
3.4 – 4.2	0.95 – 1.75	9/6.55	D3.8
3.7 – 4.2	0.95 – 1.45	9/6.25	D3.95
4.5 – 4.8	0.95 – 1.25	3.55	D4.65
7.25 – 7.75	0.95 – 1.45	6.3	D7.5*(Note1)
10.7 – 11.7	0.95 – 1.95	9.75	D11.2
10.7 – 11.75	0.95 – 2	9.75	D11.225
10.95 – 11.7	0.95 – 1.7	10	D11.35
11.2 – 12	0.95 – 1.75	10.25	D11.6
11.4 – 12.2	0.95 – 1.75	10.45	D11.8
11.45 – 12.25	0.95 – 1.75	10.5	D11.85
11.7 – 12.5	0.95 – 1.75	10.75	D12.1
11.7 – 12.75	0.95 – 2	10.75	D12.225
12.2 – 12.75	0.95 – 1.5	11.25	D12.475
12.2 – 13.25	0.95 – 2	11.25	D12.725
18.3 – 19.3	0.95 – 1.95	17.35	D18.8
19.0 – 20.0	0.95 – 1.95	18.05	D19.5
20.0 – 21.0	0.95 – 1.95	19.05	D20.5
20.2 – 21.2	0.95 – 1.95	19.25	D20.7

## MULTI-BAND BLOCK DOWNCONVERTERS

Band	Input (GHz)	Output (GHz)	LO (GHz)	Conv Tray Model #
1	10.7 – 11.45	0.95 – 1.7	9.75	D3KuL
2	11.45 – 12.2	0.95 – 1.7	10.5	
3	12.2 – 12.75	0.95 – 1.5	11.25	
1	10.95 – 11.7	0.95 – 1.7	10	D3KuL1
2	11.7 – 12.2	0.95 – 1.45	10.75	
3	12.2 – 12.75	0.95 – 1.5	11.25	
1	10.7 – 11.5	0.95 – 1.75	9.75	D3KuL2
2	11.4 – 12.2	0.95 – 1.75	10.45	
3	12.2 – 13.0	0.95 – 1.75	11.25	
1	10.7 – 11.75	0.95 – 2	9.75	D2KuL
2	11.7 – 12.75	0.95 – 2	10.75	
1	17.0 – 17.8	0.95 – 1.75	16.05	D7KaL
2	17.7 – 18.5	0.95 – 1.75	16.75	
3	18.4 – 19.2	0.95 – 1.75	17.45	
4	19.1 – 19.9	0.95 – 1.75	18.15	
5	19.8 – 20.6	0.95 – 1.75	18.85	
6	20.5 – 21.3	0.95 – 1.75	19.55	
7	21.2 – 22.0	0.95 – 1.75	20.25	

## MULTI-BAND BLOCK UPCONVERTERS

Band	Output (GHz)	Input (GHz)	LO (GHz)	Conv Tray Model #
1	0.95 – 1.45	12.75 – 13.25	11.8	U2KuL
2	0.95 – 2	13.75 – 14.8	12.8	

## BLOCK UPCONVERTERS

Input (GHz)	Output (GHz)	LO (GHz)	Conv Tray Model #
0.95 – 1.35	2 – 2.4	4.9/3.85	U2.2
0.95 – 1.525	5.85 – 6.425	7.375	U6.1INV
0.95 – 1.75	5.85 – 6.65	4.9	U6.25
0.95 – 1.825	5.85 – 6.725	4.9	U6.28
0.95 – 1.35	6.7 – 7.1	5.75	U6.9
0.95 – 1.45	7.9 – 8.4	6.95	U8.15
0.95 – 1.45	12.75 – 13.25	11.8	U13
0.95 – 1.7	13.75 – 14.5	12.8	U14.125
0.95 – 1.45	14 – 14.5	13.05	U14.25
0.95 – 1.75	17.3 – 18.1	16.35	U17.7
0.95 – 2.05	17.3 – 18.4	16.35	U17.85
0.95 – 1.25	18.1 – 18.4	17.15	U18.25
0.95 – 1.95	29 – 30	28.05	U29.5
0.95 – 1.95	30 – 31	29.05	U30.5

Note: 1. The D7.5 Block Downconverter Incorporates an inter-stage filter to attenuate the transmit frequency. Published performance will be maintained with a presence of a 7.9 GHz signal at a level of -5 dBm.

**Model Numbers consist of the frame prefix RD- followed by any combination of two module bands;**

**Example: Two channel unit: RD-D12.1/D12.1**

**Two Downconverter with two identical RF trays: 11.7-12.75 GHz to L-band**

**Example: Two channel unit: RD-D3.8/D11.2**

**One channel is 3.4-4.2 GHz to L-band (non-inverting) and the other channel is 10.7-11.7 GHz to L-band**

**Example: Two channel unit: RD-D11.8/D12.225**

**One channel is 11.4-12.2 GHz to L-band and the other channel is 12.2-12.75 GHz to L-band.**

**Example: Two channel unit: RD-U6.25/D3.8**

**One channel is L-band to 5.85-6.65 and the other channel is 3.4-4.2 GHz to L-band.**

## CONVERTER SPECIFICATIONS

INPUT CHARACTERISTICS-	UPCONVERTER	DOWNCONVERTER
Return Loss (50 Ohms)	18 dB minimum	18 dB minimum
Signal Monitor	-20 dBc nominal	
LO Leakage	N/A	-80 dBm maximum

### OUTPUT CHARACTERISTICS –

Return Loss (50 Ohms)	18 dB minimum	18 dB minimum
Signal Monitor	-20 dBc nominal	
Power Output (1dB Compression) –	+13 dBm minimum	+18 dBm minimum

### TRANSFER CHARACTERISTICS -

Gain	30 dB, $\pm 3$ dB at 23°C		35 dB, $\pm 3$ dB at 23°C				
RF Level Control	15 dB in 0.2 dB steps						
L-band Level Control	30 dB in 0.2 dB steps						
Level Stability	$\pm 0.25$ dB/day maximum at constant temperature						
Amplitude Response	$\pm 0.25$ dB/40 MHz maximum, $\pm 1$ dB maximum over RF frequency band						
Slope Adjust	0 to 6 dB						
Noise Figure at Minimum Attenuation	15 dB maximum		15 dB maximum				
	18 dB maximum $\geq 1$ GHz IF		N/A				
Image Rejection	60 dB minimum						
Third Order Intermodulation Distortion With two inband signals each at 0 dBm, measured at the output	50 dBc minimum (+25 dBm IP3)		60 dBc minimum (+30 dBm IP3)				
Spurious Outputs (Inband) –							
Signal Related	65 dBc minimum up to 0 dBm output (including 2x1 spurious on 1 GHz IF bandwidth units)						
Signal Independent	-75 dBm maximum						
Maximum Phase Noise (dBc/Hz) –	LO Frequency	Offset (Hz)					
With Maximum Reference Phase Noise:		10	100	1K	10K	100K	1M
10Hz: -120dBc/Hz,	$\leq 6.7$ GHz	-74	-84	-89	-104	-109	-123
100Hz: -145dBc/Hz,	$\leq 12$ GHz	-73	-80	-85	-100	-105	-115
1kHz: -160dBc/Hz	$\leq 16$ GHz	-71	-78	-83	-99	-103	-114
	$\leq 20$ GHz	-70	-78	-81	-97	-102	-114
	$\leq 30$ GHz	-66	-74	-78	-93	-98	-110
	Ku band Multi-band units	-50	-70	-90	-95	-95	-115
	Ka band Multi-band units	-47	-65	-85	-87	-89	-109
Frequency Stability	$\pm 2 \times 10^{-8}$ , 0° to 50°C						
Frequency Aging	5 x 10 <sup>-9</sup> /day after 24 hours on time						
Automatic Reference Configuration	External 5 or 10 MHz at +7 $\pm 3$ dBm. If external reference is below +1 dBm nominal, the converter will automatically lock to the internal reference.						
Converter Mute	60 dB minimum on summary alarm or mute command.						

### REMOTE CONTROLS

Serial Interface	RS485/RS422
Ethernet Interface	10/100Base-T Ethernet interface providing: <ul style="list-style-type: none"> <li>• HTTP-based web server</li> <li>• SNMP 1.0 configuration, Alarm reporting via SNMP Trap</li> <li>• Telnet access</li> </ul>

### INDICATOR and ALARMS

Remote Mode	Green LED (front panel)
Alarm	Red LED (front panel)
Summary Alarm	Contact closure status for DC voltage and local oscillator

## OPTIONS

### 35-1. High Performance Package -

Power Output (1 dB compression) . . . . .	20 dBm minimum (10 dBm above 21.2 GHz)
Gain Slope . . . . .	0.03 dB/MHz maximum
Level Stability . . . . .	±0.25 dB/day maximum at constant temperature, 1.0 dB peak-to-peak maximum, 0 to 50°C
Group Delay . . . . .	1 ns peak-to-peak maximum
Spurious outputs (in-band) -	
Signal related . . . . .	65 dBc minimum at 0 dBm output
Signal Independent . . . . .	-80 dBm maximum
Image Rejection . . . . .	80 dB minimum
Intermodulation Distortion (Third Order) . .	With two inband signals at 0 dBm output each, third order intermod products are less than 60 dBc min (40 dBc above 21.2 GHz
Noise Spectral Density . . . . .	-85 dBm/4 KHz maximum
AM/PM Conversion (at 0 dBm output) . . .	0.1°/dB maximum
Upconverter Mute . . . . .	80 dB minimum on summary alarm, external mute input control or remote control.
High Performance Phase Noise (dBc/Hz maximum, not available with Multi-band units) -	

LO Frequency	Offset (Hz)					
	10	100	1K	10K	100K	1M
≤ 6.7 GHz	-54	-78	-108	-115	-119	-136
≤ 12 GHz	-48	-73	-103	-112	-115	-132
≤ 17.15 GHz	-47	-70	-100	-108	-111	-128
≤ 20 GHz	-52	-67	-98	-106	-109	-126
≤ 30 GHz	-50	-64	-94	-102	-107	-124

### 35-1A. High Dynamic Range -

Power Output (1 dB compression) . . . . .	20 dBm minimum
Group Delay . . . . .	1 ns peak-to-peak maximum

### 35-1B. High Performance Phase Noise only . . .

Standard IF/RF performance.

### 35-2. Lower Gain . . . . .

20 ±3 dB at 23°C, 18 dB noise figure  
(20 dB noise figure for upconverters with 1 GHz bandwidth)  
(2x1 signal related, 65 dBc at -10 dBm output)

### 35-3. Lower Gain . . . . .

10 ±3 dB at 23°C, 20 dB noise figure  
(22 dB noise figure for upconverters with 1 GHz bandwidth)  
(2x1 signal related, 65 dBc at -10 dBm output)

### 35-4. Reference Clean-up Loop and Improved Frequency Stability . . . . .

Reference oscillator acts as an analog phase lock with a 0.1 Hz nominal loop bandwidth. Typical loop suppression of the external reference is as follows: 28 dB at 1 Hz offset, 65 dB at 10 Hz, and 100 dB at 100 Hz offset  
Frequency Stability:  $\pm 2 \times 10^{-9}$ , 0 to 50°C  
Frequency Aging:  $1 \times 10^{-9}$  per day after 24 hours operation preceded by 10 days operation.

### 35-4A. Reference Clean-up Loop . . . . .

Reference oscillator acts as an analog phase lock with a 40 Hz nominal loop bandwidth. Typical loop suppression of the external reference is as follows: 24 dB at 100 Hz offset.  
Frequency Stability:  $\pm 2 \times 10^{-8}$ , 0 to 50°C  
Frequency Aging:  $1 \times 10^{-9}$  per day after 24 hours operation preceded by 10 days operation

### 35-5. RF Signal Power Divider/Combiner . . . . .

Divides (downconverter RF input) or combines (upconverter RF output) the two RF tray signals. Insertion loss: 4 dB typical.

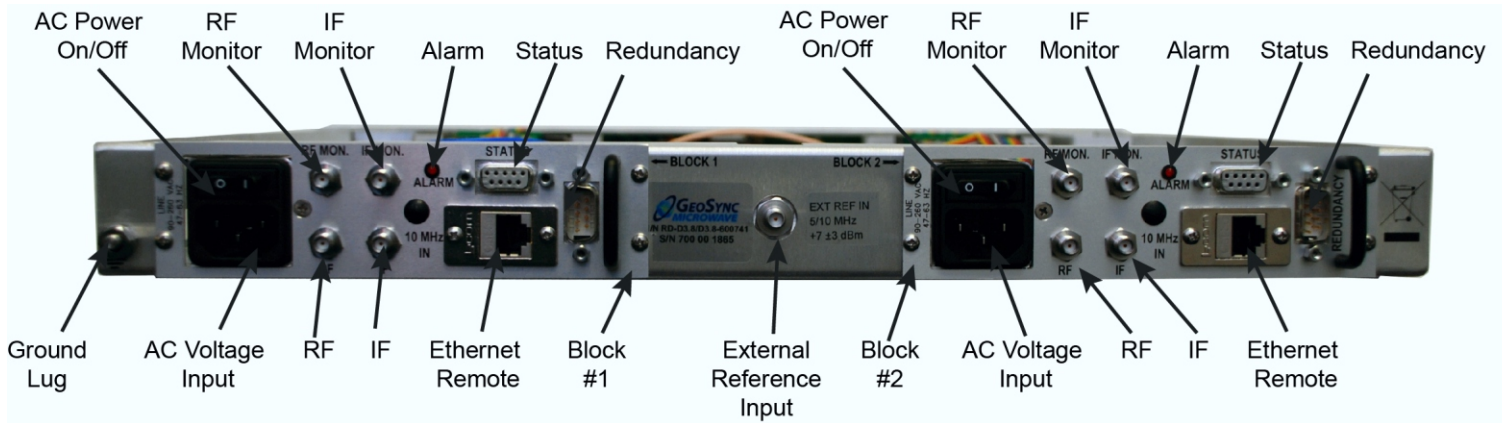

Typical rear panel view - Shown with no options

### PRIMARY POWER REQUIREMENTS

Voltage..... 90-250 VAC  
 Frequency.....47-63 Hz  
 Power Consumption .....40W typical  
 Fuses .....T1.5A

### SUMMARY ALARM

Contact closure/open for DC voltage and/or amplifier alarm. Status alarm readout on remote control bus.

### PHYSICAL

Weight ..... 12 pounds (5.4 kg), nominal without rack slides  
 16 pounds (7.3 kg), nominal with rack slides  
 Chassis Dimensions .....19" x 1.75" panel height x 20" maximum  
 Connectors -  
 RF .....SMA female (2.92 mm above 17.3 GHz)  
 Status Interface .....DE-9S  
 Redundancy Interface.....DE-9P for RS422, RS485  
 Ethernet Interface.....RJ-45 female for Ethernet  
 Primary Power .....IEC-320

### ENVIRONMENTAL

Operating -  
 Ambient Temperature ..... 0 to 50°C  
 Relative Humidity ..... Up to 95% at 30°C  
 Altitude ..... Up to 10,000 feet  
 Non-operating –  
 Ambient Temperature ..... -50 to +70°C  
 Relative Humidity ..... Up to 95% at 40°C  
 Altitude ..... Up to 40,000 feet  
 Shock and Vibration ..... Normal handling by commercial carriers

